



STANFORD

Lecture 9

Broadcast Channels (BC)

April 27, 2026

JOHN M. CIOFFI

Hitachi Professor Emeritus of Engineering

Instructor EE379B – Spring 2026

Announcements & Agenda

■ Announcements

- Problem Set #5 due Wednesday May 13
- Midterms grades (and PS4) at canvas
 - Feedback/assessment from exam

■ Agenda

- Vector Gaussian BC Design
- Worst-case-Noise BC Design
- Vector WCN-BC Design
- Maximum BC rate sum
- Midterm Review

■ Problem Set 5 = PS5 (due **May 13**)

1. 2.28 modulo precoding function
2. 2.29 scalar BC region
3. 2.30 vector BC design
4. 2.31 2-user IC region
5. 2.32 bonded relay channel



Vector MMSE BC Design

Known $R_{xx}(u)$ Section 2.8.3.1

Vector Gaussian BC

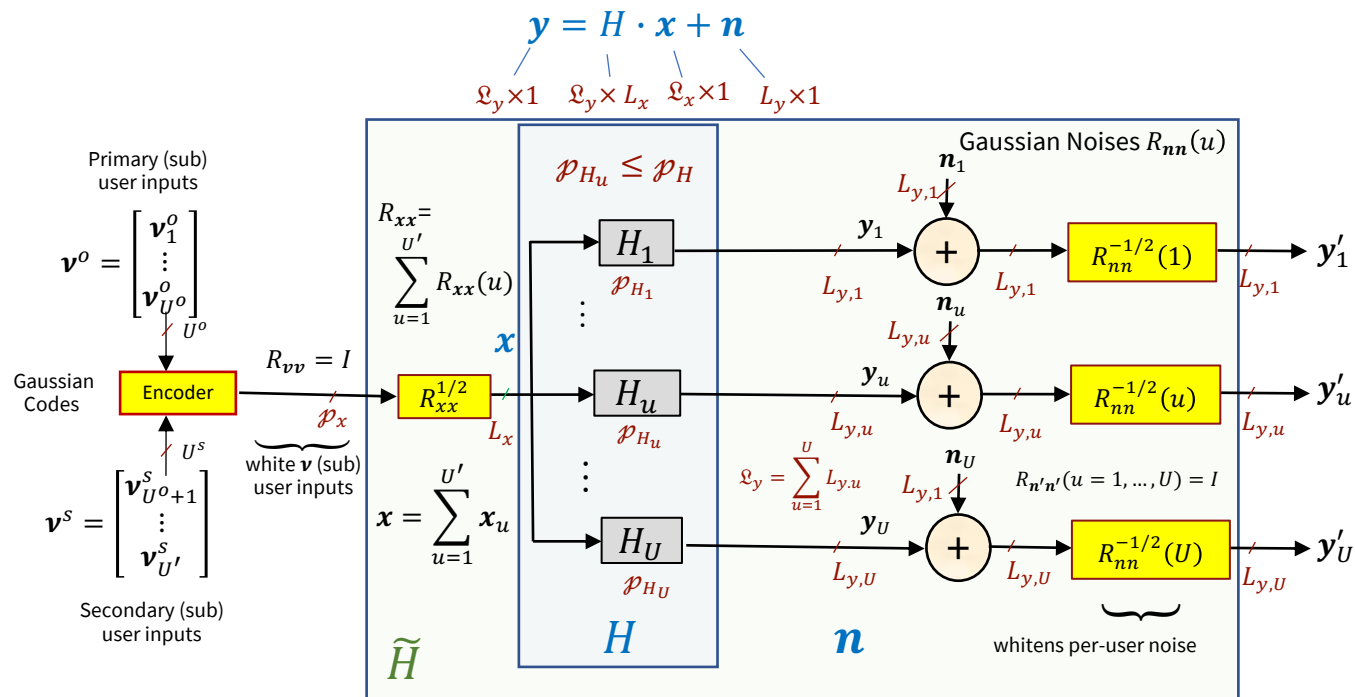

- The users' independent message subsymbol vectors sum to a single BC input x .

$$\begin{aligned} \# \text{ of subusers} = U' &\leq \sum_{u=1}^U \min(\mathcal{P}_x, \mathcal{P}_{H_u}) \leq \mathcal{L}_y \cdot L_x \\ &\leq U \cdot L_x \text{ (our designs)} \end{aligned}$$

Modulator $A = R_{xx}^{1/2}$
need not be square. It
sums all independent subusers.

MMSE – BC and Mutual Information – user u

- $\mathcal{I}(\mathbf{x}_u; \mathbf{y}_u / \mathbf{x}_{u+1, \dots, U}) = \frac{1}{2} \log_2 \frac{|R_{xx}(u)|}{|R_{ee}(u)|}$ corresponds to a MMSE problem (like MAC, except \mathbf{y}_u).

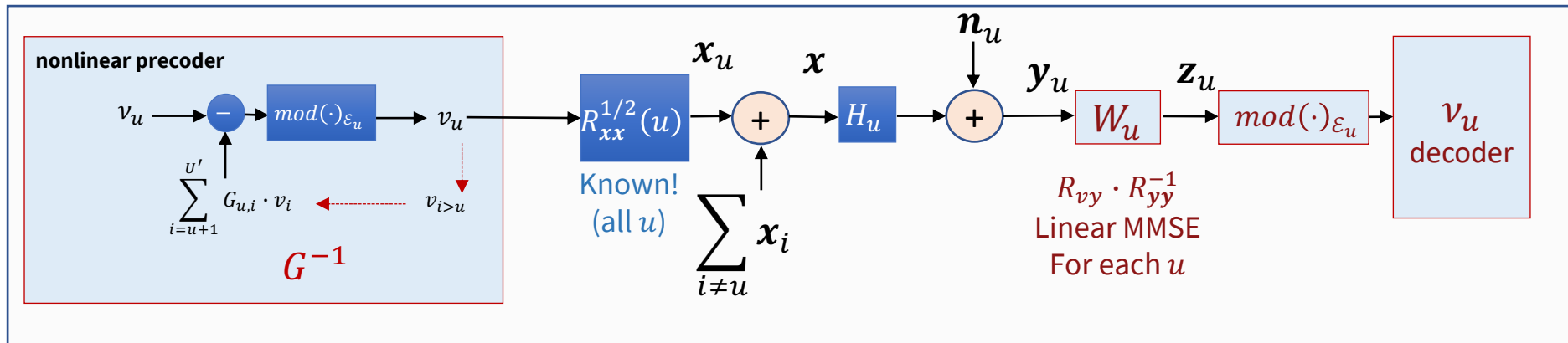

- There is successive-decoding (“GDFE”) canonical performance (up to U' components).
 - BC implements the G^{-1} with a lossless precoder at the transmitter – sum elements of $\sum_{i \neq u} \mathbf{x}_i$ are pre-cancelled.
- This structure reliably achieves highest rate for given input $R_{xx}(u)$, and order $\boldsymbol{\pi}_u$.
 - We’ll see why shortly.
- The catch? Designer must know $\{R_{xx}(\mathbf{u})\}$ and order beforehand.



Structure for all user components $u \in U'$

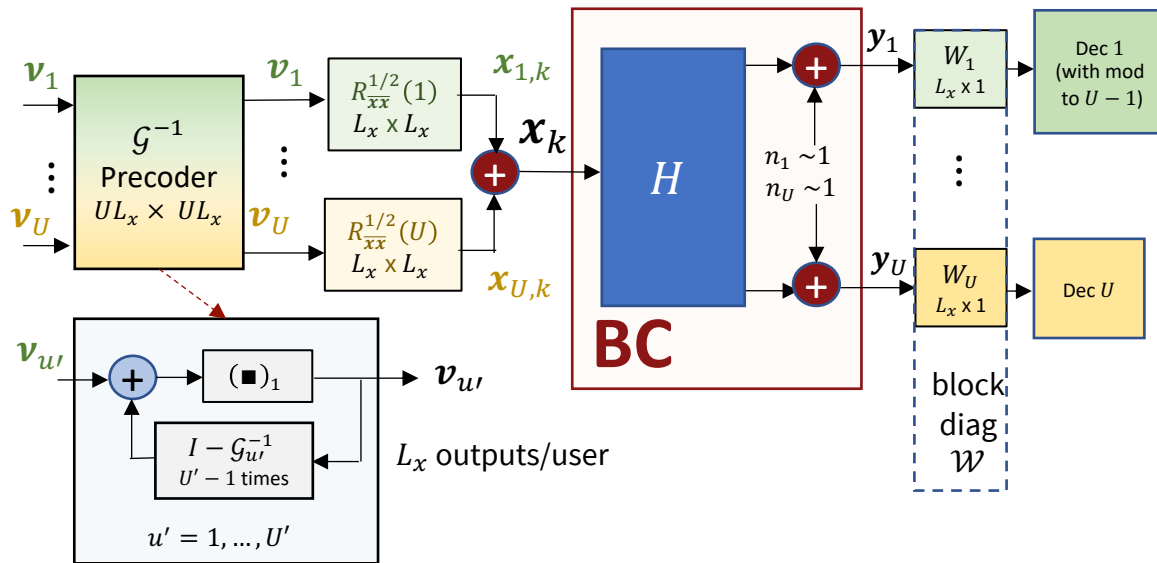

- This structure needs a little more interpretation when channel rank $<$ number of energized users.



The program mu_bc.m

```
function [Bu, GU, S0, MSWMLFunb , B] = mu_bc(H, AU, Lyu , cb)
```

Inputs: Hu, AU , Usize, cb

Outputs: Bu, Gunb, Wunb, S0, MSWMLFunb

H: noise-whitened BC matrix [H1 ; ... ; HU] (with actual noise, not wcn)
sum-Ly x Lx x N

AU: Block-row square-root discrete modulators, [A1 ... AU] **Set N = 1 (for now)**

Lx x (U * Lx) x N

Lyu: # of (output, Lyu) dimensions for each user U ... 1 in 1 x U row vector

cb: = 1 if complex baseband or 2 if real baseband channel

GU: unbiased precoder matrices: (Lx U) x (Lx U) x N

For each of U users, this is Lx x Lx matrix on each tone

S0: sub-channel dimensional channel SNRs: (Lx U) x (Lx U) x N

MSWMLFunb: users' unbiased diagonal mean-squared whitened matched matrices

For each of U cells and Ntones, this is an Lx x Lyu matrix

Bu - users bits/symbol 1 x U

the user should recompute SNR if there is a cyclic prefix

B - the user bit distributions (U x N) in cell array

- L8:32's blue rate vectors correspond to this.

- This channel's rate sum is already close to maximum, which occurs at $b = 6.3220$.

```
>> H =
    80
    50
>> Lyu=[1 1];
>> [Bu, Gunb, S0, MSWMLFunb] = mu_bc(H, [1/sqrt(2) 1/sqrt(2)], Lyu, 2)
Bu =
    5.8222    0.4997
>> Gunb{:,:} =
    1.0000    1.0000
---
     0     1
S0 =
2 x 1 cell array
{[3.2010e+03]} User 1 SNR
{[ 1.9992]} User 2 SNR
MSWMLFunb =
2 x 1 cell array
{[0.0177]} multiplies y1
{[0.0283]} multiplies y2
>> sum(Bu) = 6.3219
>> [Bu, GU, S0, MSWMLFunb , B] = mu_bc(H, [1 0], 1 , 2);
>> B = 1 x 1 cell array {[6.3220]}
```

Equal energy on both users

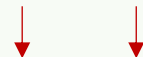

G adds user 2 to user 1 - we already knew this

Add nothing to user 2

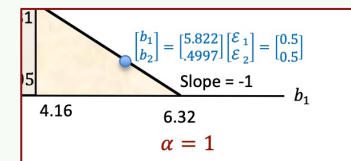

Receivers are each simple scaling



More Examples

```
H=[50 30
10 20];
>> A =
    0.5000    0 0.5000    0
    0 0.5000    0 0.5000
[Bu, Gunb, S0, MSWMMFunb] = mu_bc(H, A, [1 1], 2);
```

$U' = U \cdot L_x = 4$ subuser components

```
Bu =
4.8665 0.4971
```

```
>> Gunb{:,;} =
    1.0000    0.6000    1.0000    0.6000
    0    1.0000    1.6667    1.0000
```

user 1's own xtalk and user 2 also

```
-----
    0    0    1.0000    2.0000
    0    0    0    1.0000
```

user 2's own xtalk

```
>> MSWMMFunb{:,;} =
    0.0400
    0.0667
-----
    0.2000
    0.1000
```

Each receiver estimates 2 input dimensions for its user, each a subuser.

```
>>> S0{:,;} =
    626.0000    0
    0    1.3594
-----
    1.1984    0
    0    1.6623
```

User 1's dimensional SNR's

User 2's dimensional SNR's

```
>> sum(Bu) = 5.3636
```

- mu_bc.m solves two MMSE problems here (for receiver 1 and receiver 2).
- It also aggregates them into right places in single matrix (cell array) of feedback/precoder, receiver filters.
- The receiver filters' rows apply to only their specific user/component (subuser) through MSWMMFunb.



Worst-Case-Noise BC Design

Sections 2.8.3.2 and 2.8.3.5

$L_{y,u} = 1$ Case: finding the primary components

- Find each user's normalized channel $\tilde{H}_u \triangleq R_{nn}^{-1/2}(u) \cdot H_u$.
- Later \rightarrow a general ($L_{y,u} > 1$) way that uses worst-case noise; however, $L_{y,u} = 1$ is simpler to describe.

$$y_u = \tilde{h}_{u,1} \cdot x_1 + \dots + \tilde{h}_{u,L_x} \cdot x_{L_x}$$

- Find largest BC element, initialize $I_{BC} = J_{BC} = U$:

- This becomes user i_1 and is first in order π .

$$h_{max} = \max_{i,j} |\tilde{h}_{i,j}| \quad i \in I_{BC} \wedge j \in J_{BC}$$

- Find next largest channel gain with user 1 as noise:

$$\tilde{h}_{max} = \max_{i,j} |\tilde{h}_{i,j}|^2 / (|\tilde{h}_{i,i_1}|^2 + 1) \quad \forall i \in \{I_{BC} \setminus i_1\} \wedge j \in \{J_{BC} \setminus \{i_1\}\}$$

- That is user i_2 and is second in order π .

- This continues recursively $U^o = \wp^H$ times.
- Any energy on users $\{\min(L_x, \wp_H) + 1, \dots, U\}$ reduces rate sum and is from secondary components.



Worst-Case Noise (2.8.3.3)

- “Worst-case” noise has covariance R_{nn} that minimizes $\mathcal{I}(\mathbf{x}; \mathbf{y})$ for a fixed R_{xx} .
 - Only the receivers’ local noises $R_{nn}(u)$ are fixed, but the correlation between different user/receivers’ noise may vary.
- Thm: $R_{wcn}^{-1} - [H \cdot R_{xx} \cdot H^*]^{-1} + R_{psd} = \mathcal{S}_{wcn}$ where \mathcal{S}_{wcn} is $\mathcal{L}_y \times \mathcal{L}_y$ block (sub-block sizes $L_{y,u}$) diagonal.
 - Further: $\mathcal{P}_{R_{wcn}} = \mathcal{P}_{\mathcal{S}_{wcn}} = \#$ of primary components = U^0 .
 - Further: The secondary components correspond to \mathcal{S}_{wcn} ’s zeroed diagonal elements (equivalently nonzero elements correspond to primary components).
 - R_{psd} is a Lagrange constraint for the positive semidefinite nature of the worst-case noise, and \mathcal{S}_{wcn} is the Lagrange constraint for the block diagonal noises. R_{psd} is absent unless R_{wcn} is singular – many treatments ignore the singular case, but it occurs often in field.
- Proof: See notes (also Appendix C on matrix calculus).
- When noise has R_{wcn} , the MMSE estimate $\hat{\mathbf{v}} = W \cdot \mathbf{y}$ has W that **IS DIAGONAL (block)**.

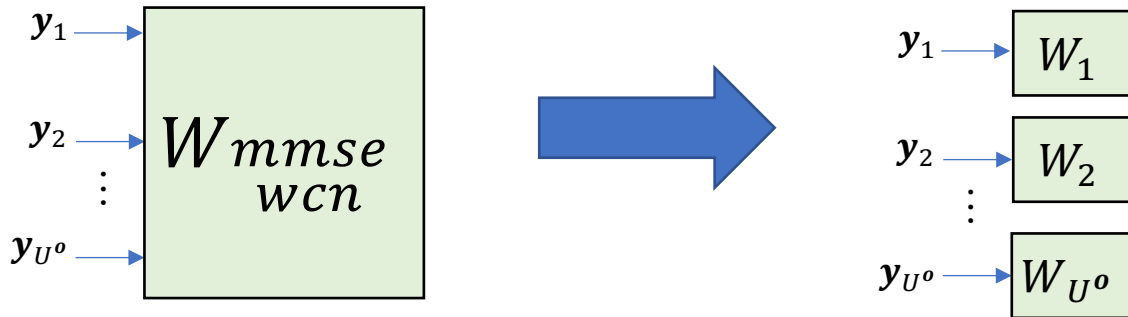

So, WCN corresponds to best BC receiver(s)

$$b = \mathcal{I}_{wcn}(\mathbf{x}; \mathbf{y})$$



▪ Energized secondary components simply “free load” on the primary-components’ dimensions.

Remove Singularity and now Precode

- Now with known primary (sub-) users, original channel's SVD (no noise-whiten) is $H \cdot R_{xx}^{1/2} \triangleq \begin{bmatrix} F & f \\ 0 & 0 \end{bmatrix} \begin{bmatrix} \Lambda & 0 \\ 0 & 0 \end{bmatrix} \begin{bmatrix} M^* \\ m^* \end{bmatrix}$.
- Input transforms to $x \rightarrow M \cdot v$ (M becomes part of square root, & relabel); $H \cdot R_{xx}^{1/2} \rightarrow F\Lambda$.

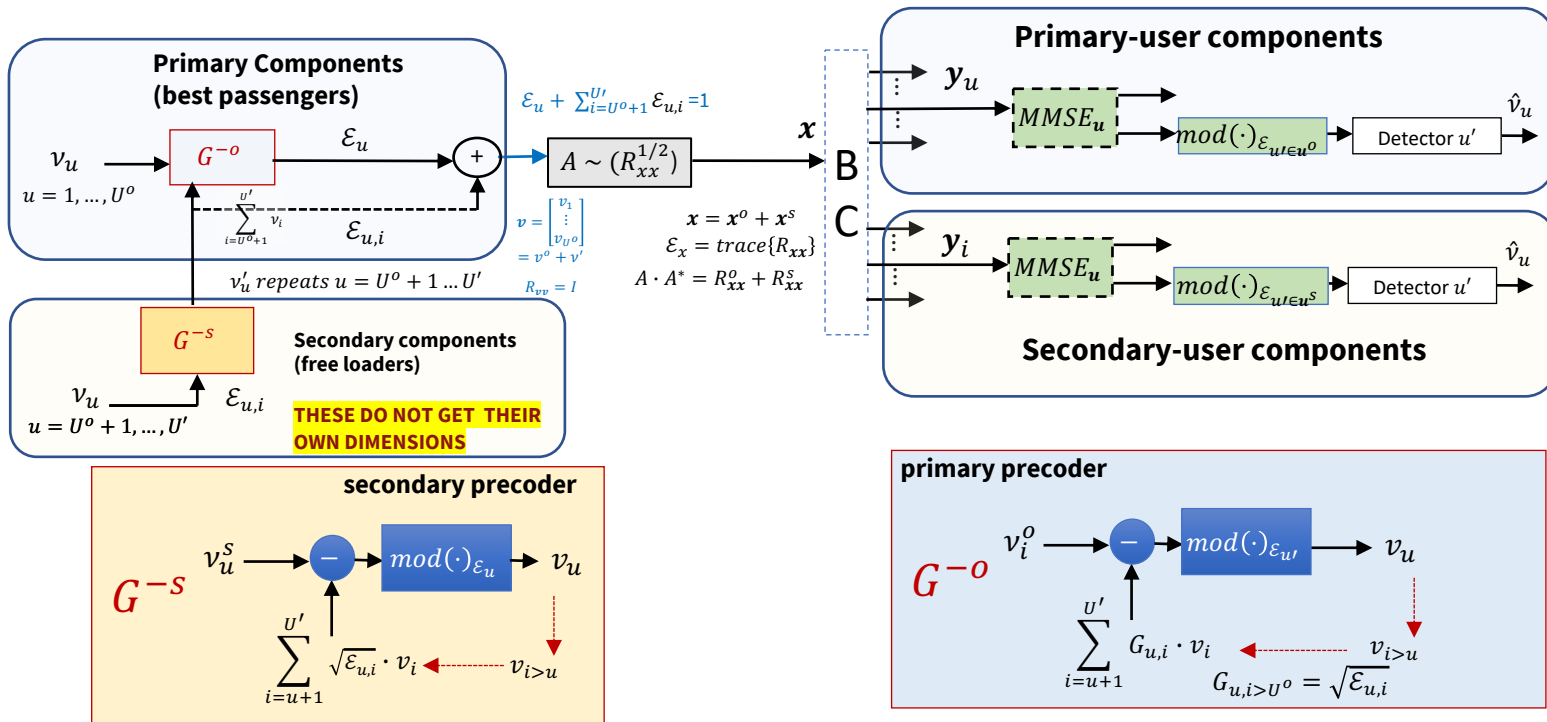

Mohseni's nonsingular-WCN Program (no CVX)

```
function [Rwcn, bsum] = wcnoise(Rxx, H, Ly, dual_gap, nerr)
```

inputs

H is $U \times L_y$ by L_x , where

L_y is the (constant) number of antennas/receiver,

L_x is the number of transmit antennas, and

U is the number of users. H can be a complex matrix

Rxx is the L_x by L_x input (nonsingular) autocorrelation matrix

which can be complex (and Hermitian!)

dual_gap is the duality gap, defaulting to $1e-6$ in wcnoise

nerr is Newton's method acceptable error, defaulting to $1e-4$ in

wcnoise

outputs

Rwcn is the $U \times L_y$ by $U \times L_y$ worst-case-noise autocorrelation matrix.

bsum is the rate-sum/real-dimension.

$I = 0.5 * \log(\det(H^*Rxx^*H^*+Rwcn)/\det(Rwcn))$, Rwcn has $L_y \times L_y$ diagonal blocks that are each equal to an identity matrix

Example

```
>> H=[80
50] =
    80
    50      (noise-whitened/normalized channel)
>> [Rwcn,b]=wcnoise(1,H,1,1e-6,1e-4)
Rwcn =
    1.0000    0.6250
    0.6250    1.0000
b =    6.3220.
```

```
>> Htilde=inv(Rwcn)*H =
    80.0000
    0.0000
>> Swcn=inv(Rwcn)-inv(H*H' + Rwcn). =
    0.9998    0.0000
    0.0000    0.0000
>> Ryy=H*H'+Rwcn =    1.0e+03 *
    6.4010    4.0006
    4.0006    2.5010
>> SNRp1=det(Ryy)/det(Rwcn) = 6.4010e+03
>> 0.5*log2(SNRp1) = 6.3220 (checks!)
```

▪ $S_{wcn}(u, u)$ = sensitivity to $R_{nn}(u)$ change, if = 0 \rightarrow secondary user.

▪ Note WCN program permits easy sketch of the capacity region.

• Hint: you know noise-free user 1, and you also know the sum, so user 2's rate is the difference (PS5.3).



Singular 3x3 BC, nonsingular WCN

```
>> H =
```

```
80 60 40
60 45 30
20 20 20
```

```
>> Rxx =
```

```
3 0 0
0 4 0
0 0 2
```

```
>> [Rwcn, b]=wcnnoise(Rxx, H, 1, 1e-5, 1e-4);
```

```
>>Rwcn
```

```
1.0000 0.7500 0.0016
0.7500 1.0000 0.0012
0.0016 0.0012 1.0000
```

```
>> b
```

```
11.3777
```

```
>> Swcn=inv(Rwcn)-inv(H*Rxx*H'+Rwcn) =
```

```
0.9995 0.0000 0.0000
0.0000 -0.0000 0.0000
0.0000 0.0000 0.9948
```

- Works for any R_{xx} **IF** WCN produced is nonsingular

```
>> sr=[5 0 0
```

```
7 8 9
```

```
10 11 12];
```

```
>> Rxx=sr*sr' =
```

```
25 35 50
35 194 266
50 266 365
```

```
>> [Rwcn, b]=wcnnoise(Rxx, H, 1, 1e-5, 1e-4);
```

```
>> Rwcn
```

```
1.0000 0.7500 0.0002
0.7500 1.0000 0.0001
0.0002 0.0001 1.0000
```

```
>> b = 16.4029
```

```
>> Swcn=inv(Rwcn)-inv(H*Rxx*H'+Rwcn)
```

```
Swcn =
```

```
0.9999 0.0000 0.0000
0.0000 -0.0000 -0.0000
0.0000 -0.0000 0.9996
```

- Note position of zeros – user 2 is a single secondary component.
- wcnnoise.m is sufficient if WCN is nonsingular.
- Nonsingular R_{xx} forces ID of secondary components (WCN nonsingular).



Liao's Generalized Worst-Case Noise (uses CVX)

```
function [Rnn, sumRatebar, S1, S2, S3, S4] = cvx_wcnoise(Rxx, H, Lyu)
```

cvx_wcnoise This function computes the worst-case noise for any given input autocorrelation Rxx and channel matrix.

Arguments:

- Rxx: input autocorrelation, size(Lx, Lx)
- H: channel response, size (Ly, Lx)
- Lyu: number of antennas at each user, scalar/vector of length U

also allows variable number of antennas/user – not so in wcnoise.m

Outputs:

- Rnn: worst-case noise autocorrelation, with white local noise
- sumRatebar: maximum sum rate/real-dimension
- S1 is the lagrange multiplier for the real part of Rnn diagonal elements. Zero values indicate secondary users.
- S2 is the imaginary part
- S3 is for the positive semidefinite constraint on Rwc
- S4 is for a larger Schur compliment used in the optimization

S1 and S2 together are S_{wcn} ; S2 prevents quantization-error accumulation on imaginary part

S3 plus S4 together in upper $U \times U$ positions equal S_{wcn}

- This program accommodates singular WCN (which is common in well-designed systems).
- The S3 plus S4 are the R_{psd} value, which must add to the S_{wcn} (block) diagonal = S1, see text 2.8.3.3.
- Secondary users are only identified when R_{xx} is nonsingular or if singular, the best or “water-filling for WCN” case,
 - recalling that secondary identification occurs only for maximum rate sum.



Singular WCN

- Can occur if input is lower rank (optimization):

```
>> H =  
0.4054 - 0.1990i 0.3641 + 0.6869i 3.6004 + 0.5569i 0.5318 + 0.0080i  
1.8406 + 1.3469i -1.3014 - 1.1630i 2.7217 + 1.0820i 0.0947 - 1.0710i  
-2.3367 + 1.1594i -0.3949 + 0.7899i -1.4024 + 0.8380i 0.8085 + 0.3019i  
1.1210 + 1.4423i 0.2611 + 1.6376i 2.9534 - 0.3945i 0.2962 - 0.8347i
```

```
>> Rxx =  
0.1382 + 0.0000i 0.0077 - 0.0664i -0.0701 + 0.0449i -0.0594 - 0.0207i  
0.0077 + 0.0664i 0.2005 + 0.0000i -0.0155 - 0.0152i 0.0281 - 0.0130i  
-0.0701 - 0.0449i -0.0155 + 0.0152i 0.0522 + 0.0000i 0.0262 + 0.0288i  
-0.0594 + 0.0207i 0.0281 + 0.0130i 0.0262 - 0.0288i 0.0331 + 0.0000i
```

```
>> rank(H) = 3  
>> rank(Rxx) = 2  
>> [V, D]=eig(Rxx);  
diag(D) = -0.0001 0.0001 0.1418 0.2821  
>> Rxx=V(:,3)*V(:,3)*D(3,3)+ V(:,4)*V(:,4)*D(4,4);  
rank(iRxx) = 2
```

Only Necessary
for copy-paste.

```
[F,L,M]=svd(H);  
diag(L) = 6.7116 3.1056 2.0988 0.0000  
H=F(:,1)*M(:,1)*L(1,1)+ F(:,2)*M(:,2)*L(2,2)+F(:,3)*M(:,3)*L(3,3);  
rank(H) = 3
```

- 0 sensitivity with singular WCN may **not** identify secondary user,
 - which is the last user here (rank(Rxx)=2 falsely makes another appear secondary).
- It is secondary, **IF** also maximum rate sum (see L10).

```
[>> [Rwcn, b , S1, S2, S3, S4] = cvx_wcnoise(Rxx, H, ones(1,4))  
Rwcn =  
1.0000 + 0.0000i -0.5084 + 0.0458i 0.1251 + 0.5916i -0.0042 + 0.3065i  
-0.5084 - 0.0458i 1.0000 + 0.0000i -0.4394 + 0.2473i -0.6341 + 0.0932i  
0.1251 - 0.5916i -0.4394 - 0.2473i 1.0000 + 0.0000i 0.7215 + 0.3923i  
-0.0042 - 0.3065i -0.6341 - 0.0932i 0.7215 - 0.3923i 1.0000 + 0.0000i  
>> rank(Rwcn) = 3  
b = 0.8241  
S1 = 4x1 cell array  
{[ 0.2288]}  
{[ 0.3149]}  
{[ 0.3073]}  
{[5.9295e-09]}  
S2 = 4x1 cell array  
{[0]}  
{[0]}  
{[0]}  
{[0]}  
S3+S4(1:4,1:4) =  
0.2288 0 0 0  
0 0.3149 0 0  
0 0 0.3073 0  
0 0 0 0.0000  
>> pinv(Rwcn)*H = 1.0e+09*  
1.0647 + 0.7898i -0.1492 + 0.2605i 2.1940 + 0.5313i 0.1632 - 0.5248i  
0.4982 + 1.1166i -0.2378 + 0.1418i 1.5228 + 1.4199i 0.3687 - 0.3479i  
-0.6578 + 1.1464i -0.2754 - 0.1173i -0.2699 + 2.2345i 0.5387 + 0.1003i  
-0.0000 - 0.0000i 0.0000 - 0.0000i -0.0001 - 0.0000i -0.0000 + 0.0000i
```

User 4 is Secondary



3 BC Cases

Perfect MIMO: $U^o = U'$. This case is non-degraded since $U' = \varrho_H = \varrho_x$; there are no secondary components. Perfect MIMO users each have equal number of used transmitter dimensions (antennas) and total number of receiver dimensions (antennas). Perfect MIMO's (all-primary-component) dimensions each have a path largely (MMSE sense) free of other users' crosstalk, as becomes evident shortly. Essentially, all the user components get their own dimension.

Degraded (NOMA): $U^o < U'$. In NOMA, $U^o = \min(\varrho_h, \varrho_x) \leq U'$ and secondary components have no dimensions (antennas) to themselves. In this case, energy-sharing (or sharing the secondary components' data rates on common dimensions) is necessary if the secondary components must carry non-zero information. However, the $H_{u \in \mathbf{u}^s}$ determine these secondary components' maximum reliably decodable rates, even though the primary-component receivers could reliably decode a higher rate for these secondary components.

Enlarged MIMO: $U^o > U'$. This case corresponds to at least one individual user's receiver having $L_{y,u} > 1$; there are multiple receiver dimensions (antennas) per user. There are two sub-cases:

1. $U < U^o < U'$ (**degraded enlarged MIMO**). In this case some components may share dimensions to receivers, and there are secondary components.
2. $U < U^o = U'$ (**non-degraded enlarged MIMO**). In this case, each component has at least one dimension that is largely free (MMSE sense) of crosstalk from other components.

When $U^o \gg U$, enlarged (non-degraded) MIMO often has the name "**Massive MIMO**."

- Wi-Fi, 4G/5G, Vector DSL (sometimes called MU-MIMO) are all "perfect MIMO."
- Time-sharing (TDMA) really just increases channel rank until perfect MIMO, not optimum, & extra delay.
- NOMA is more general; IoT, Metaverse, FWA when congested are NOMA.



Vector WCN-BC Design

PS5.3 - 2.30

Vector BC Design

WCN Design focuses on primary users

- Any secondary-user components “free load” on the dimensions best used by primary-user components.
- Delete the secondary-user components’ rows from \tilde{H} .
- The precoder-coefficients’ design, which pre-inverts channel, depends on those primary components.
 - Any energized secondary components “dimension-share” those primary dimensions (and reduce overall rate sum).
- This design method can provide BC insights.
- Chapter 5 will find a way for any desired $\mathbf{b}' \in \mathcal{C}(\mathbf{b})$ to derive the $\{R_{xx}(u)\}$, but the choice of \mathbf{b}' (scheduling) may want to know about primary/secondary components.
- **Every user component has its own single-user good code (so use your 379A favorite code).**



Only for primary users (\rightarrow **NONSINGULAR WCN**)

- Use R_{wcn} directly:
 - General S_{wcn} is block diagonal.
 - Find A .

$$R_{wcn}^{-1} = [H \cdot A \cdot A^* \cdot H^* + R_{wcn}]^{-1} = S_{wcn}$$

- Indeed, that is the backward MMSE channel in there!

$$S_{wcn} = R_{wcn}^{-1} - [R_{wcn}^{-1} - R_{wcn}^{-1} \cdot H \cdot A (I + A^* \cdot H^* \cdot R_{wcn}^{-1} \cdot H \cdot A)^{-1} A^* \cdot H^* \cdot R_{wcn}^{-1}]$$

$$Q_{wcn}^* \cdot S'_{wcn} \cdot Q_{wcn} = R_{wcn}^{-1} \cdot H \cdot A \underbrace{\left(I + A^* \cdot H^* \cdot R_{wcn}^{-1} \cdot H \cdot A \right)^{-1}}_{R_b \triangleq G^{-1} \cdot S_0^{-1} \cdot G^{-*}} A^* \cdot H^* \cdot R_{wcn}^{-1} \quad (2.432)$$

- Q_{wcn} is also block diagonal.

$$S'_{wcn} = \underbrace{Q_{wcn} \cdot R_{wcn}^{-1} \cdot H \cdot A}_{\text{triangular inverse}} \cdot \underbrace{R_b}_{\text{diagonal}} \cdot \underbrace{A^* \cdot H^* \cdot R_{wcn}^{-1} \cdot Q_{wcn}^*}_{\text{triangular inverse}}, \quad (2.433)$$

- QR factorization (primaries' channel)

- extract $A = R_{xx}^{1/2}$ from tri inverse,
- which is the forward channel.

$$Q_{wcn} \cdot R_{wcn}^{-1} \cdot H = \begin{bmatrix} \mathbf{0} & \mathbf{R} \\ \hline (L_x - U^o) \times U^o & U^o \times U^o \end{bmatrix} \begin{bmatrix} \mathbf{q} \\ \mathbf{Q}^* \\ \hline U^o \times L_x \end{bmatrix} = R \cdot Q^*$$

- Cholesky factorization the input.

$$\Phi \cdot \Phi^* = Q^* \cdot R_{xx} \cdot Q$$

- A special square root!

- "pre-triangularizes" the channel,
- which becomes $R \cdot \Phi$.

$$R_{xx}^{1/2} = A = Q \cdot \Phi$$

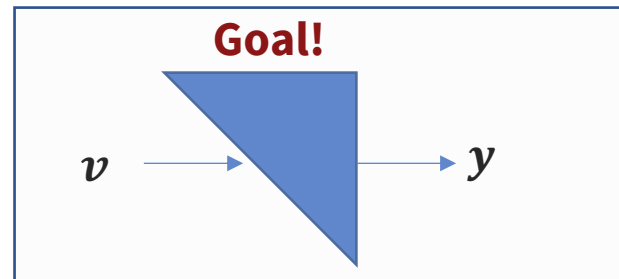

The precoder

- Design wants monic G for precoder:

$$D_A \triangleq \text{Diag}\{R \cdot \Phi\}$$

Find diagonal values

$$G = D_A^{-1} \cdot R \cdot \Phi$$

$$S_0 = D_A \cdot (S')_{wcn}^{-1} \cdot D_A$$

Monic Equivalent

- Check = R_b for G and S_0 :

$$G^{-1} \cdot S_0^{-1} \cdot G^{-*} = (\Phi^{-1} \cdot R^{-1} \cdot D_A) \cdot (D_A^{-1} \cdot S_{wcn} \cdot D_A^{-1}) \cdot (D_A \cdot R^{-*} \cdot G^{-*}) \quad (2.441)$$

$$= \Phi^{-1} \cdot R^{-1} \cdot S_{wcn} \cdot R^{-*} \cdot \Phi^{-*} \quad (2.442)$$

$$= \Phi^{-1} \cdot R^{-1} \cdot [Q_{wcn} \cdot R_{wcn}^{-1} \cdot H \cdot A \cdot R_b \cdot A^* \cdot H^* \cdot R_{wcn}^{-1} \cdot Q_{wcn}^*] \cdot R^{-*} \cdot \Phi^{-*}$$

$$= \Phi^{-1} \cdot R^{-1} \cdot R \cdot Q^* \cdot Q \cdot \Phi \cdot R_b \cdot \Phi^* \cdot R^* \cdot R^{-*} \cdot A \cdot Q^* \cdot \Phi^{-*} \quad (2.443)$$

$$= R_b \quad (2.444)$$

- Check SNR and mutual-info:

$$2^{\mathcal{I}_{wcn}(\mathbf{x}; \mathbf{y})} = \frac{|H \cdot R \mathbf{x} \mathbf{x} \cdot H^* + R_{wcn}|}{|R_{wcn}|}$$

$$= |R_{wcn}^{-1/2} \cdot H \cdot R \mathbf{x} \mathbf{x} \cdot H^* \cdot R_{wcn}^{*/2} + I|$$

$$= |R_{wcn}^{-1/2} \cdot H \cdot A \cdot A^* \cdot H^* \cdot R_{wcn}^{*/2} + I|$$

$$= |A^* \cdot H^* \cdot R_{wcn}^{-1} \cdot H \cdot A + I| \quad \text{follows from SVD of } R_{wcn}^{-1/2} \cdot H \cdot A$$

$$= |R_b^{-1}|$$

$$= |S_0|$$

$$\mathcal{I}_{wcn}(\mathbf{x}; \mathbf{y}) = \log_2(|S_0|) \quad \text{bits/complex subsymbol.}$$

Works!



The (single-user) best receiver with WCN

- The MMSE receiver is block diagonal(!)
 - for WCN only, but is
 - just what the BC needs

$$\begin{aligned} W &= \underbrace{S_0^{-1} \cdot G^{-*}}_{1-to-1} \cdot \underbrace{A^* \cdot H^* \cdot R_{wcn}^{-1}}_{\text{noise-white-match}} \cdot \underbrace{Q_{wcn}^* \cdot Q_{wcn}}_I \\ &= S_0^{-1} \cdot G^{-*} \cdot \Phi^* \cdot Q^* \cdot Q \cdot R^* \cdot Q_{wcn} \\ &= S_0^{-1} \cdot G^{-*} \cdot \Phi^* \cdot R^* \cdot Q_{wcn} \\ &= S_0^{-1} \cdot G^{-*} \cdot G^{-1} \cdot D_A \cdot Q_{wcn} \\ &= S_0^{-1} \cdot D_A \cdot Q_{wcn} \quad , \end{aligned}$$

- Design has same bias removal as with all MMSE.

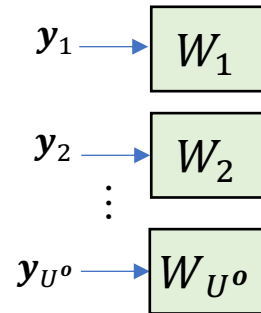

BC WCN-Design Steps Summary (2.8.3.3)

Special Square Root

- Find R_{wcn} - this step also finds \mathcal{S}_{wcn} and also the primary/secondary users and $b_{max}(R_{xx})$.
 - Delete rows/columns (secondary sub user dimensions) with zeros from \mathcal{S}_{wcn} , and correspondingly then in R_{wcn} .
- If \mathcal{S}_{wcn} is non-trivial (block diagonal MIMO), form $\mathcal{S}_{wcn} = Q_{wcn}^* \cdot \mathcal{S}'_{wcn} \cdot Q_{wcn}$ (eigen decomp).
- Perform QR factorization on $Q_{wcn} \cdot R_{wcn}^{-1} \cdot H = R \cdot Q^*$ where R is upper triangular, and Q is unitary.
- Perform Cholesky Factorization on $Q^* \cdot R_{xx} \cdot Q = \Phi \cdot \Phi^*$ where Φ is also upper triangular.
- And now, the special square root is $R_{xx}^{1/2} = Q \cdot \Phi$ (see diagram L10:22 = A).

Precoder and Diagonal Receiver

- Find the diagonal matrix $D_A = \text{Diag}\{R \cdot \Phi\}$.
- Find the (primary sub-user) precoder $G = D_A^{-1} \cdot R \cdot \Phi$ (monic upper triangular).
- Find the backward MMSE (block) diagonal matrix $S_0 = D_A \cdot (S')_{wcn}^{-1} \cdot D_A$ (note, $R_b^{-1} = G^* \cdot S_0 \cdot G$).
- Block diagonal (unbiased) receiver is $W_{unb} = (S_0^{-1} - I)^{-1} \cdot D_A \cdot Q_{wcn}$.
- Can check, but $b_{max}(R_{xx})$ from WCN will be $\mathcal{I}_{wcn}(\mathbf{x}; \mathbf{y}) = \log_2 |S_0| = \sum_{u=1}^{U^o} \log_2 (1 + SNR_{BC, wcn, u})$.

Other data rate vectors b then share this system between primary/secondary.



Example – all primary

- Energy $\mathcal{E}_x = 2$, $L_x = 2$

```
>> H = [80 70 ; 50 60];  
>> Rxx=[1 .8 ; .8 1];
```

```
>> [Rwcn,b]=wcnnoise(Rxx,H,1)
```

```
Rwcn =  
1.0000 0.0232  
0.0232 1.0000
```

Nonsingular Rwcn

```
b = 9.6430
```

```
>> Swcn = inv(Rwcn)-inv(H*Rxx*H'+Rwcn) =  
0.9835 0.0000  
0.0000 0.9688
```

```
>> Htilde=inv(Rwcn)*H =  
78.8817 68.6440  
48.1687 58.4064
```

```
>> [R,Q,P]=rq(Htilde)  
R =  
-12.4389 -74.6780  
0 -104.5673
```

```
Q =  
0.6565 -0.7544  
-0.7544 -0.6565
```

```
P = 2 1
```

ORDER IS REVERSED SO SWITCH USERS!

```
J=[0 1; 1 0];
```

```
>> Rxxrot=Q'*Rxx*Q;  
>> Phi=lohc(Rxxrot) =  
0.4482 0.0825  
0 1.3388  
>> DA=diag(diag(R*Phi));  
>> G=inv(DA)*R*Phi =  
1.0000 18.1182  
0 1.0000  
>> A=Q*inv(R)*DA*G =  
0.2942 -0.9557  
-0.3381 -0.9411  
>> S0=DA*inv(Swcn)*DA = 1.0e+04 *  
0.0032 -0.0000  
-0.0000 2.0229  
Wunb=inv((S0)-eye(2))*DA*J  
-0.0000 -0.1822  
-0.0069 -0.0000  
Indeed diagonal with order switch!  
>> Gunb=eye(2)+S0*inv(S0-eye(2))*(G-eye(2)) =  
1.0000 18.7103  
0 1.0000  
>> b=0.5*log2(diag(S0))' = 2.4909 7.1521  
>> sum(b) = 9.6430 (checks)
```

```
>> J*Wunb*H*A*inv(Gunb) =  
0.0386 >> -0.0004  
0.0236 << 25.4902
```

Diagonal (or almost)

Parallel Channels!.

Try different
Input Rxx,
See text, Ex 2.8.7



Return to Design

- The design can allocate R_{xx} energy to secondary and primary users as

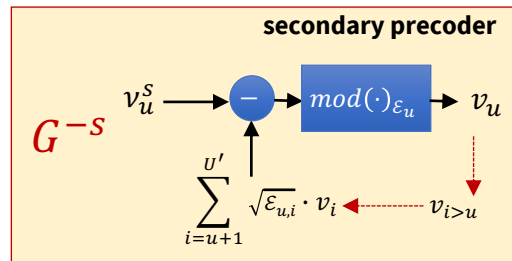
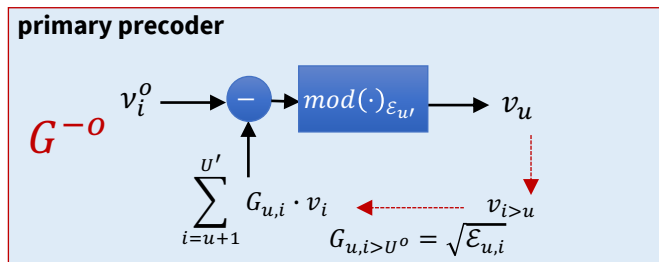

- The receivers are GDFE for primary users.
- Just decode with user-specific MMSE design for secondary receivers, for which corresponding users have codes with lower rates than could be decoded at the primary receivers.

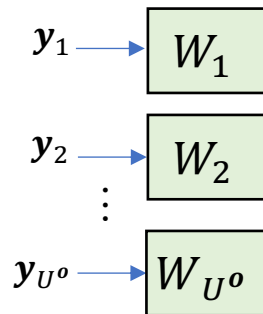

Another example – singular 3x3 BC (Ex 2.8.8)

```
>> H=[80 60 40
60 45 30
20 20 20];
>> rank(H) = 2
>> Rxx=diag([3 4 2]);
>> [Rwcn1, b]=wcnoise(Rxx, H, 1, 1e-5, 1e-4);
>> Rwcn1
    1.0000    0.7500    0.0016
    0.7500    1.0000    0.0012
    0.0016    0.0012    1.0000
>> b = 11.3777
>> Swcn=inv(Rwcn1)-inv(H*Rxx*H'+Rwcn1) =
    0.9995    0.0000    0.0000
    0.0000   -0.0000    0.0000
    0.0000    0.0000    0.9948
```

User 2 is secondary – remove for now

```
>> H1=[H(1,1:3)
H(3,1:3)]=
    80    60    40
    20    20    20
>> [Rwcn, b]=wcnoise(Rxx, H1, 1, 1e-5, 1e-4);
>> Rwcn =
    1.0000    0.0016
    0.0016    1.0000
>> b = 11.3777
>> Swcn=inv(Rwcn)-inv(H1*Rxx*H1'+Rwcn) =
    0.9995    0.0000
    0.0000    0.9948
```

Primary/Secondary

```
>> [R,Q,P]=rq(inv(Rwcn)*H1)
R =
    0    9.1016   -33.2537
    0    0   -107.6507
Q =
    0.4082   -0.5306   -0.7429
   -0.8165    0.1517   -0.5571
    0.4082    0.8340   -0.3713
P = 2 1
ORDER IS REVERSED (Here it is order of
users 1 and 3 since 2 was eliminated)
>> R1=R(1:2,2:3);
>> Q1=Q(1:3,2:3);
>> Rxxrot=Q1'*Rxx*Q1 =
    2.3275    0.2251
    0.2251    3.1725
>> Phi=lohc(Rxxrot);
>> DA=diag(diag(R1*Phi)) =
    13.8379    0
    0   -191.7414
>> G=inv(DA)*R1*Phi =
    1.0000   -4.1971
    0    1.0000
>> A=Q1*inv(R1)*DA*G =
   -0.8067   -1.3902
    0.2306   -0.9730
    1.2679   -0.5559
>> A*A' =
    2.5833    1.1667   -0.2500
    1.1667    1.0000    0.8333
   -0.2500    0.8333    1.9167
```

Not equal to Rxx
Energy not inserted into
null space (same on part
that is in pass space)

Sq Root & Precoder

```
>> S0=DA*inv(Swcn)*DA = 1.0e+04 *
    0.0192    0.0000
    0.0000    3.6957
>> MSWMFunb=inv((S0)-eye(2))*DA*J =
    0.0000    0.0726
   -0.0052   -0.0000
>> Gunb=eye(2)+S0*inv(S0-eye(2))*(G-eye(2)) =
    1.0000   -4.2191
   -0.0000    1.0000
>> b=0.5*log2(diag(S0))' =
    3.7909    7.5868
>> sum(b) = 11.3777 checks
>> H*A =
    0.0219  -191.8333
    0.0164 -143.8749
    13.8379  -58.3825
See Example 2.8.8 or details of below
Assign 1 energy unit to User 1, 1/3 to user 3, and now squeeze in
2/3 energy on user 2
>> b=0.5*log2(diag([1 1/3]) *diag(S0)) =
    3.7909
    6.7943
Crosstalk is >> ct=1/3*143.9^2 = 6.8928e+03
>> b2=0.5*log2(1+(2/3)*60^2/6892.8) = 0.2155
>> b2+sum(b) = 10.8007 < 11.3777
```

$$\frac{1}{\sqrt{2/3} + \sqrt{1/3}}$$

Energy on secondary reduces rate sum



System Diagram for this WCN design

$$v_1 = \sqrt{\mathcal{E}_1} \cdot v_1^o + \sqrt{\mathcal{E}_{1,2}} \cdot v_2$$

$$v_3 = \sqrt{\mathcal{E}_3} \cdot v_3^o + \sqrt{\mathcal{E}_{3,2}} \cdot v_2$$

$$GU = \begin{bmatrix} 1.0000 & -4.2191 \\ -0.0000 & 1.0000 \end{bmatrix}$$

$$MSWMFU = \begin{bmatrix} -13.7657 & 0.0000 \\ -0.0000 & 191.7362 \end{bmatrix}$$

See Ex 2.8.8

$$\mathbf{x} = \underbrace{\begin{bmatrix} -0.8067 & -1.3902 \\ 0.2306 & -0.9370 \\ 1.2679 & -0.5559 \end{bmatrix}}_A \cdot \begin{bmatrix} \sqrt{\mathcal{E}_1} & \sqrt{\mathcal{E}_{12}} & 0 \\ 0 & \sqrt{\mathcal{E}_{23}} & \sqrt{\mathcal{E}_3} \end{bmatrix} \begin{bmatrix} v_1 \\ v_2 \\ v_3 \end{bmatrix}$$

Try: $\mathcal{E}_1 = 1$ and $\mathcal{E}_{12} = 0$
 $\mathcal{E}_3 = \frac{2}{6}$ and $\mathcal{E}_{32} = \frac{4}{6}$

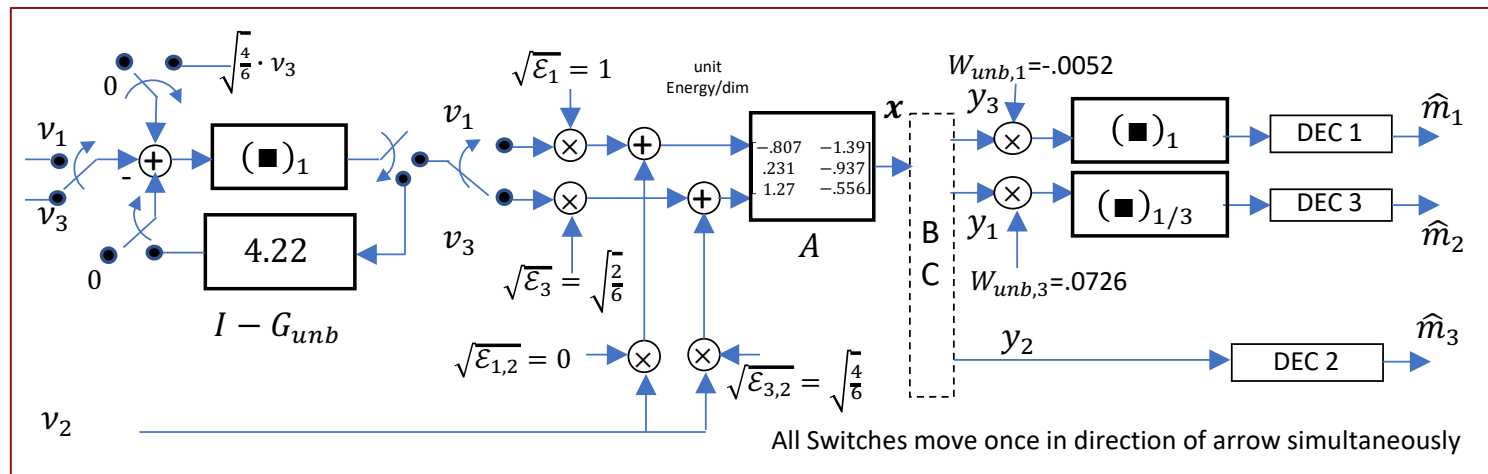

Gaussian Vector BC System Diagram

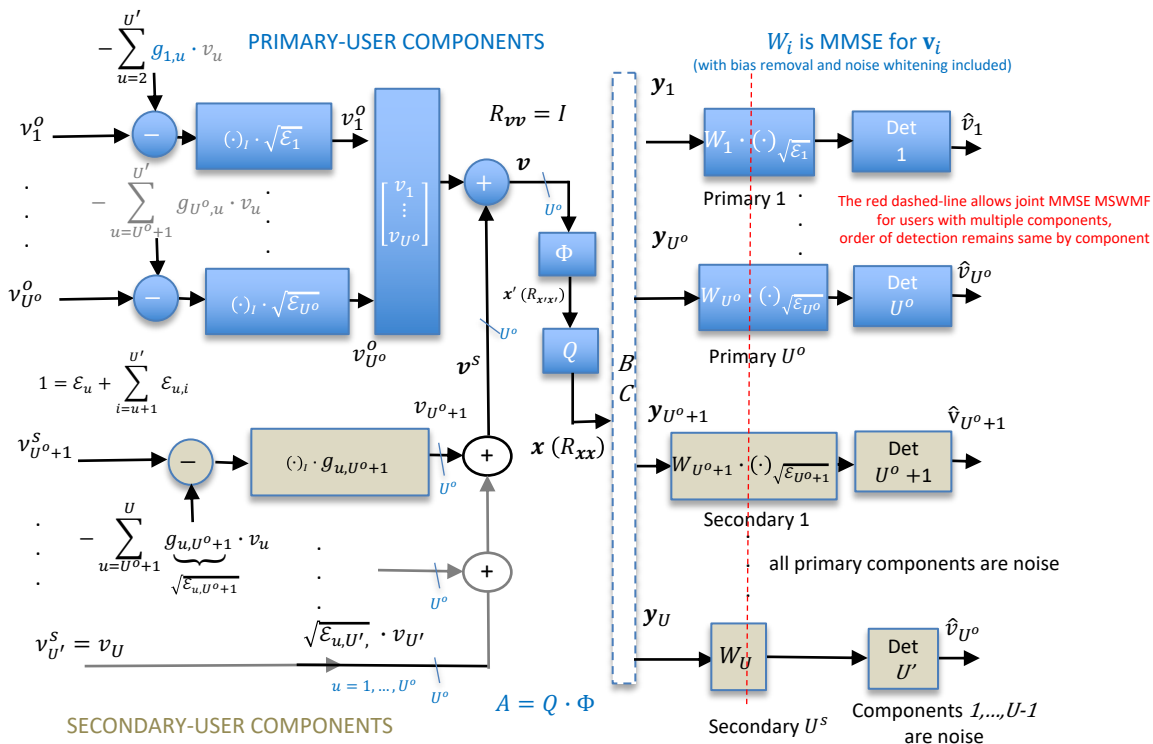

- This design is for any R_{xx} , but the square root $Q \cdot \Phi$ is very special and unique; this design is for the R_{wcn} , no matter the real correlation between receiver noises; U' is number of user components.



Midterm Review

- Questions
- Advice





End Lecture 9